

EE40 Final Project

a) Page 1: Overview

i. Name(s) and SIDs of project partner(s)

- Szu-Han Charles Wang 20481793
- Peter Hu 20645539

ii. Title of project

- Electronic Light Sensor Siren Synthesizer

iii. Short description of project objective and results

Our project is inspired by a Japanese science book called *Electronic Circuit Design*. On page 94 it describes the application of a light dependence resistor on a common toy: a bird which sings a song when illuminated. The key idea behind the circuit is the use of a cadmium sulfide (CdS) cell, a light dependent resistor which varies its resistor value depending on the intensity of the illuminating light. Thus, we can apply this property to achieve our objective: use light as source to determine the behavior of our device.

We use the concept from LAB4 of using resistors and capacitors to control timer circuits to synthesize frequencies used in sirens. The 555 Timer is our most important component, as the clock on and off rate can be set by different values of capacitors and resistors. Behind it is the RC circuit, which has charging and discharging periods that determine the clock on and off periods of the timer circuits. Since the CdS cell varies its resistance based on the amount of light it receives, the capacitor charging and discharging time will vary based on the amount of light the CdS receives. The 8-pin 555 Timer will generate a voltage with frequency based on the capacitor charge and discharge time and this varying voltage will be the input to the speaker, so the varying resistance value will create varying frequencies emitted by the speaker.

Finally, we put our circuit bread board inside a car model. More light illuminating the car will cause it to sing with higher frequency. This is because more light decreases the CdS resistor value, and we will show that this decreases the capacitor charging time, which results in a lower frequency.

iv. List of references you used for your design (books, articles, websites)

- Tatsuo Inami, *Electronic Circuit Design*
- <http://www.micro-examples.com/public/microex-navig/doc/200-pic-microcontroller-examples.htm>
1
- <http://delabs-circuits.com/cirdir/theory/tutors/doc00009.html>

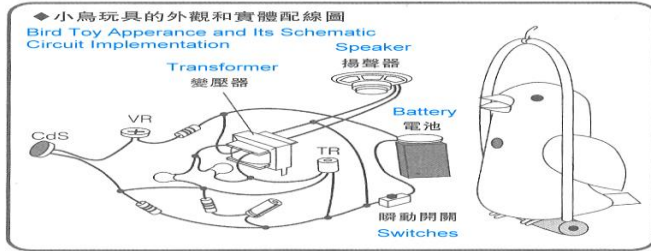

b) Page 2: Annotated circuit schematic including component values. Arrange symbols logically on the page and draw neatly.

● Main Components:

1. SPEAKER, 8 OHM .5W 45MM LOW PRO
2. SWITCH PB SPST ALT ACT PC MOUNT
3. PHOTOCCELL 10K-200K OHM 4.20MM
4. LED BAR GRAPH 10-SEGMENT GREEN
5. RESISTORS
6. CAPACITOR
7. LM555 TIMER

● Photocell (Light Dependent Resistor) Description:

- Name: CdS Photoconductive Photocells PDV-P9008
- Image: see top right
- Features: low cost, visible light response
- Applications: camera exposure, shutter controls, night light controls
- Brief description: The PDV-P9008 are CdS, Photoconductive photocells are designed to sense light from 400 to 700 nm. These light dependent resistors are available in a wide range of resistance values. They are packaged in a two leaded plastic-coated ceramic header.
- Values: $R(\text{dark}) = 20 \text{ M Ohm}$
 $R(\text{illuminated}) = 10\sim 200 \text{ K Ohm}$
 (10K Ohm when 10 lx @ 2856 K)



● Component Values: see graph below

RA is composed of two photocells in parallel to lower resistance

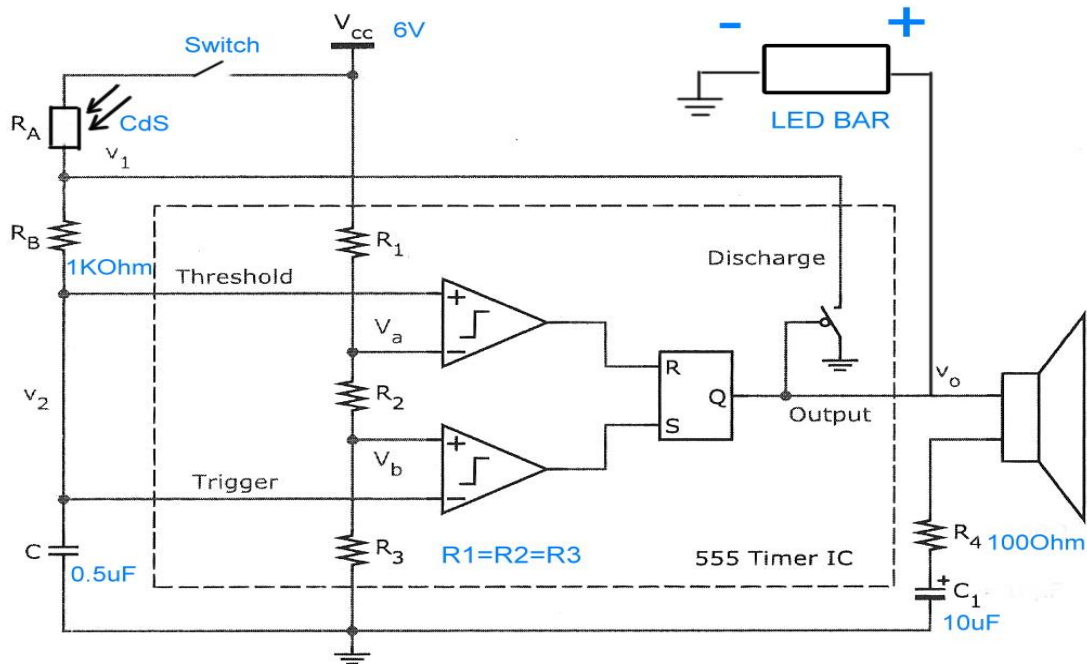

c) Page 3: Demonstrate your understanding of the circuit with a brief description of its operation including key circuit analysis and design equations, including numerical values.

The switch between V_{cc} and R_A is a button that when turned off (open switch), will prevent any charge from getting to capacitor C , meaning the LM555 will output 0V and the speaker and LED bar will be off.

We use the same configuration as in LAB4 for the astable operation of the timer; the capacitor C is periodically charged and discharged by the circuit. We replace R_A by CdS to generate different frequencies. The CdS resistance decreases as the intensity of light incident to its surface increases. This means the capacitor charging time decreases as more light reaches the photocells. Lowering the capacitor charging time means the period T decreases, so the frequency output by the timer will increase as R_A decreases, as our equations below demonstrate. Since the capacitor discharge time is only dependent on R_B , it will remain constant throughout the circuit's operation. Thus, only the variation in the capacitor charging time will affect the LM555's output frequency.

This is a description from the LM555 data sheet:

The LM555 is a highly stable device for generating accurate time delays or oscillation. For astable operation as an oscillator, the free running frequency and duty cycle are accurately controlled with two external resistors and one capacitor. (quoted from data sheet)

The LED bar is connected to the LM555 output. Since the bar will be on when the voltage across it is V_{cc} and off when the voltage across it is 0V, we expect the LED bar to flicker at the frequency of the LM555 output. Since we cannot see changes at such a high frequency, the LED will appear to be constantly on.

Below is the general waveform diagram for astable operation. We calculate t_1 , t_2 :

➤ Charge time(output high): $0.5V_{cc} = V_{cc} (1 - e^{-(t_1/\tau)})$, where $\tau = (R_A+R_B) C$

➤ Discharge time(output low): $0.5V_{cc} = V_{cc} * e^{-(t_2/\tau)}$, where $\tau = (R_B) C$

So we get $t_1 = 0.693 (R_A+R_B) C$, $t_2 = 0.693 R_B C$

$T = t_1 + t_2 = 0.693 (R_A+2R_B) C$

$f = 1 / T = 1.44 / ((R_A+2R_B) C)$

Chart: Frequency vs. Position

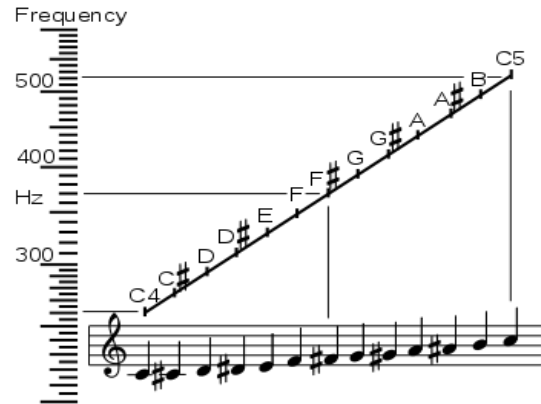
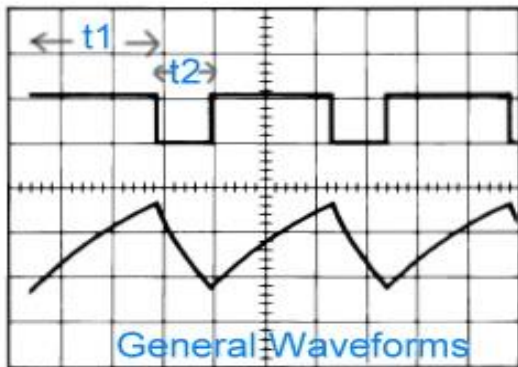

d) Page 4: Describe how you verified your circuit including relevant measurement results (e.g. oscilloscope screen shots). Explain possible shortcomings of your design and how they could be overcome.

- Simulation from SPICE:
- Estimated Values:

Light position	RA(Ohm)	RB(Ohm)	C(F)	T1(s)	T2(s)	T(s)	F(Hz)
Normal	3.436K	1K	0.5u	1.537m	0.346m	1.884m	530.8
Covered	4.425K	1K	0.5u	1.880m	0.346m	2.226m	449.2
7.5cm	0.512K	1K	0.5u	523.9u	0.346m	870.4u	1149
15cm	2.08K	1K	0.5u	1.067m	0.346m	1.414m	707.2
30cm	2.68K	1K	0.5u	1.275m	0.346m	1.622m	616.5

- Test the real circuit:

Lab Data: (T1 is the period for charging; T2 is the period for discharging); $T = T_1 + T_2$

Light position	CdS(Ohm)	Vo(p-p)(V)	Vo(avg)(V)	T1(s)	T2(s)	T(s)	F(Hz)
Normal	3.436K	1.953	3.060	1.09m	0.5m	1.59m	628.9
Covered	4.425K	1.562	3.217	1.50m	0.25m	1.749m	571.8
7.5cm	0.512K	1.989	3.027	957.1u	2.9u	960.0u	1042

15cm	2.08K	1.734	3.124	1.2m	0.162m	1.362m	734.2
30cm	2.68K	1.865	3.208	1.45m	0.602m	2.052m	487.3

After pushing the switch button, we see the LED bar light up, and we hear the sound from the speakers. If we put the circuit under a lamp or shine a flashlight on the photocells, the speaker sound pitch will increase significantly. On the other hand, if we use hands to cover the photocells, the sound frequency will decrease. At very low frequencies the sound becomes nearly inaudible. To gather data, we shine a flashlight on the photocells, holding the flashlight at distances specified on the table. When comparing our experimental results with the expected values, we see they are generally close to the expected values. The reason for some discrepancies is probably because of some variation between the actual height we hold the flashlight and the recorded height. This discrepancy should be small however, so a more significant factor is probably that the beam from the flashlight probably hits the surface of the photocells at an angle. The photocells are very sensitive to light variation, and it is very difficult to ensure that the flashlight beam hits the photocells at the same angle on every trial, so this is probably a primary cause of differences between the experimental data and calculated values. However, the oscilloscope graphs of voltage across C have the same form as those from the SPICE simulation, so we can conclude that generally the circuit works as expected. One thing we noticed about the circuit however, is that even when the button is off, the circuit draws power from the batteries, meaning that the batteries will die quickly if we leave them connected to the circuit. From this it is possible to suppose that the off state of the switch is created by using a large resistance value, but this means power is still being drawn from the batteries. It does not appear that we can resolve this problem with our current components.